

ATEX LED INSPECTION LEADLAMP



WITHOUT COMPROMISE

SP-600H, SP-600L & SP-600EL ZONES **1** **2** **21** **22**

PRODUCT INFORMATION

The ATEX LED Inspection Leadlamp SP-600 is a cable-powered, versatile and lightweight handheld light with impressive LED light output, making it ideal for inspection and work activities in Hazardous Areas; Marked to the ATEX directive and IECEx certified safe for use in Zone 1 potentially explosive gas atmospheres, where a T4 temperature class permits, and Zone 21 potentially explosive dust atmospheres.



KEY INFORMATION

CERTIFICATION

- ATEX and IECEx Approved for Zone 1/21 explosive gas and dust atmospheres
- IP Rating: certified to IP67, the SP-600 is dust tight and protected against powerful water jets and immersion up to 1 metre (30 minutes max)

AMBIENT APPROVED

- -30°C to +55°C

LIGHT OUTPUT

- 470 lumens at source
- High power white LED with a wide 180° beam
- LED light source 'fitted for life' with 60,000+ hours life.

FEATURES

- Cable powered with optional fixings such as supplied detachable hook, or fixing magnet (SP-624) enabling easy deployment for hands free activities
- Ergonomic handle for inspection tasks even with gloved hands
- Durable polycarbonate enclosure with a scratch and chemical resistant hardcoat construction
- Multiple power options available to accommodate supply power, from 9-16VAC/DC, 18-54VAC/20-54VDC & 90-264VAC
- Optional fixing cage (SP-600) to help minimise damage to the lamp, prolonging the lifespan
- Swivel adjustment within frame to direct light accordingly

TECHNICAL INFORMATION

LIGHT OUTPUT DIAGRAM

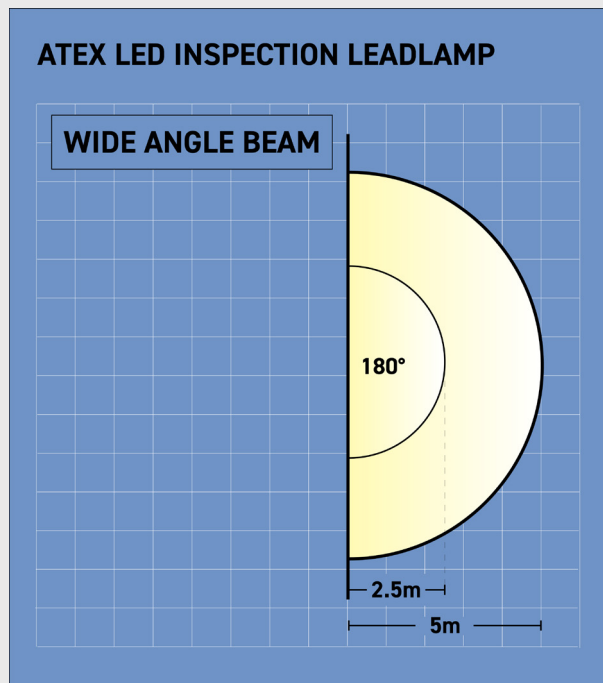

Beam 180°

470 lumens (at source) / 403 lumens (from leadlamp)

Peak Illuminance at 1m **93 lux**, 2.5 **14.9 lux**, 5m **3.72 lux**

PRODUCT DIMENSIONS

SP-600H, SP-600L,
SP-600EL

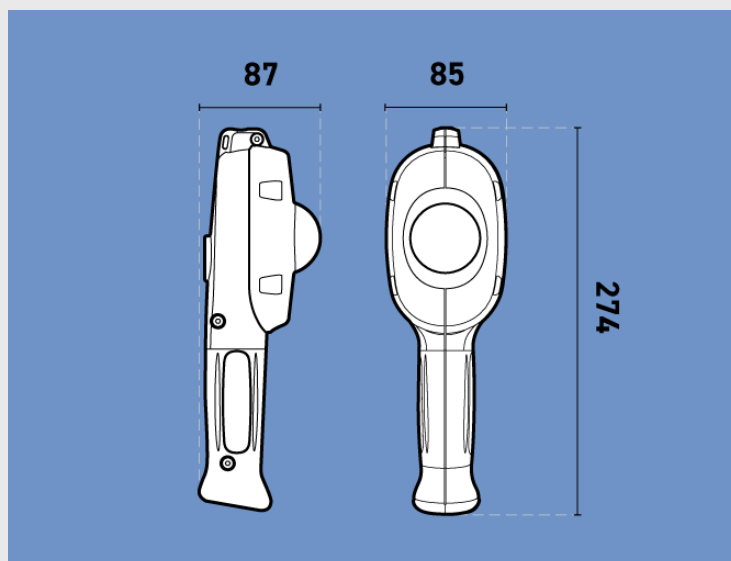

MEASUREMENT MM



ATEX/IECEX LED MINI WORKLITE™ WL-50

PRODUCT REFERENCE	SP-600H	SP-600L	SO-600EL
PRODUCT DESCRIPTION	ATEX Zone 0 Flood Bank		
	High (H)	Low (L)	Extra Low (EL)
CODE	I M2 Ex eb mb I Mb (-30°C to +55°C) II 2G Ex eb mb IIC T4 Gb IP67 II 2D Ex mb tb IIIC T95°C Db		
TYPE OF PROTECTION	'eb' Increased Safety, 'mb' Encapsulation, 'tb' Dust Ignition Protection by Enclosure		
AREA OF CLASSIFICATION (GAS)	Zones 1 & 2 Gas Groups IIA, IIB & IIC		
TEMPERATURE CLASSIFICATION	T4		
AREA OF CLASSIFICATION (DUST)	Zones 21 & 22 Dust Groups IIIA, IIIB & IIIC		
MAX. SURFACE TEMPERATURE (DUST)	T95°C		
AMBIENT TEMPERATURE	-30°C to +55°C		
CERTIFICATE	SIRA15ATEX3317X IECEX SIR15.0115X		
ENCLOSURE	High Impact, Anti-Static Polypropylene		
LENS	Polycarbonate, Scratch and Chemical Resistant Hardcoat		
LIGHT SOURCE:	TYPE	High Power LED	
	POWER/OUTPUT	470 lumens (at source) / 403 lumens (from leadlamp)	
	LIFE	60 000 Hrs	
POWER SOURCE:	VOLTAGE	90-264VAC	18-54VAC 20-54VDC
	PLUG	No plug supplied as standard	
	CABLE	10m HOFR 2 core x 1.5 mm ²	
INGRESS PROTECTION	IP67		
WEIGHT	1.785 kg		

All information has been gathered under laboratory conditions, the user must regard the values given as approximate. Changes may be made to the above specification without notification, details are available on request.



Wolf Safety Lamp Company
Saxon Road Works, Sheffield S8 0YA, UK

T: +44 (0) 114 255 1051
E: info@wolfsafety.com

