

# HAZARD LAMP



WITHOUT COMPROMISE

HL-95 ZONES **0** **1** **2**

## PRODUCT INFORMATION

The HL-95 Hazard Lamp is a semi-portable, free standing illuminated warning device CE marked to the ATEX directive and UKEX certified for safe use in Zones 0, 1 or 2 Hazardous Areas.

### FEATURES

- Approved for safe use in Zones 0,1 or 2
- Flashing or static output selectable
- Operation in flashing mode up to 2 months
- Daylight cut-out mode selectable
- Ultra-bright L.E.D light source
- 180° bi-directional lens arrangement
- Highlighting obstacles in hazardous areas
- Effective demarcation of hazardous area zones



HL-95 Hazard Lamp

### NSN Codes

6120-99-7091078 - HL-95MOD

## TECHNICAL INFORMATION

### PRODUCT DIMENSIONS

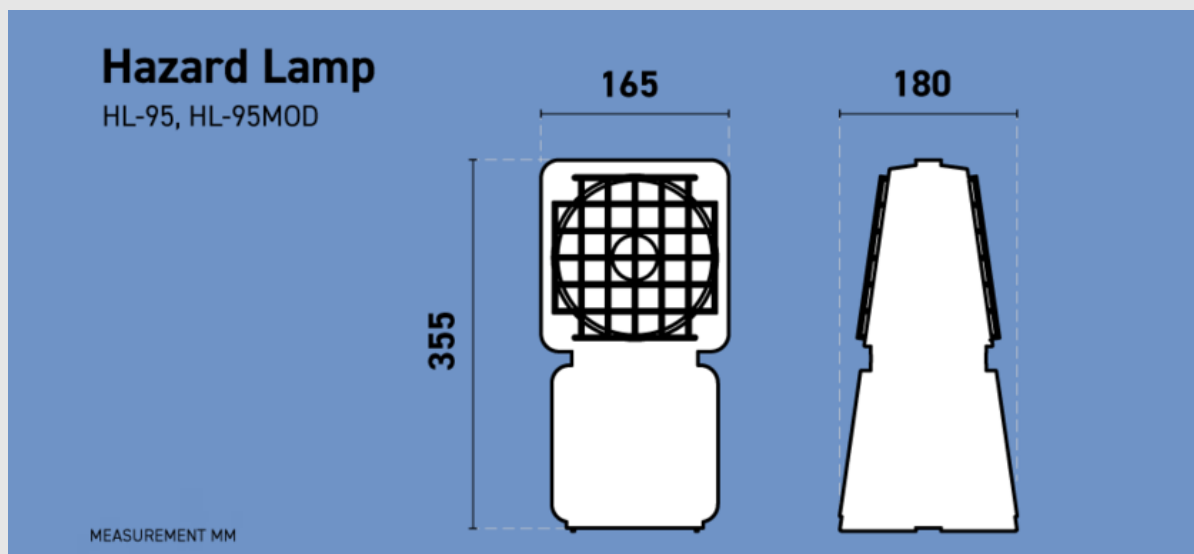

# TECHNICAL INFORMATION

HAZARD LAMP		
PRODUCT REFERENCE	HL- 95	
PRODUCT DESCRIPTION	Primary Battery Operated Safety Hazard Lamp	
CODE	II 1 G Ex ia op is IIC T4 Ga	
TYPE OF PROTECTION	"ia" intrinsic safety	
AREA OF CLASSIFICATION (GAS)	Zones 0,1 and 2, Gas Groups IIA, IIB and IIC	
TEMP. CLASSIFICATION	T4	
AMBIENT TEMPERATURE	-10°C to +40°C	
CERTIFICATE	BAS 99 ATEX 1044X / BAS21UKEX0434X	
ENCLOSURE	Static dissipative polypropylene with metal lens guard	
LENS	Amber Transparent plastic	
LIGHT OUTPUT	> 2cd	
LIGHT SOURCE	TYPE	Solid State LED
	COLOUR	Amber
POWER SOURCE	PART NUMBER	HL-3155X
	TYPE	Air Depolarised Primary Cell Battery
	VOLTS	5.6v
	CAPACITY	40Ah
BATTERY WEIGHT	1.7kg	
BATTERY DIMENSIONS	L 110 x W 110 x H 140 mm	
LIGHT DURATION	1500 hours flashing mode, 500 hours static mode	
INGRESS PROTECTION	IP21	
WEIGHT (INCL.BATTERY)	2.9kg	

Changes may be made to the above specification without notification, details are available on request. All information has been gathered under laboratory conditions, the user must regard the values given as approximate.



Wolf Safety Lamp Company  
Saxon Road Works, Sheffield S8 0YA, UK

T: +44 (0) 114 255 1051  
E: [info@wolfsafety.com](mailto:info@wolfsafety.com)

