

# Portable Ventilators for Hazardous Locations

Applicable Models:

UB20xx	EFi120xx
EFi75xx	EFi150xx

**UK**  
**CA**  
**0843**

**CE**  
**0539**



**II 2 G Ex db eb IIB T6 Gb**  
**II 2 G Ex h IIB T6 Gb**  
0539 Demko 09 ATEX 0926969X  
IECEX UL 13.0062X  
UL23UKEX2861X

Segurança



The Portable Ventilators described herein are intended for use in Explosive Atmospheres in accordance with the limitations of the rating. It is the user's responsibility to determine the suitability of equipment for the intended purpose.

## TECHNICAL INFORMATION AND ORIGINAL INSTALLATION INSTRUCTIONS



Euramco Group | 2746 Via Orange Way, Spring Valley CA 91978 USA  
Ph: +1-619-670-9590 | [www.euramco.com](http://www.euramco.com)

SM-EFATEX REV H5

## WARNING!

These units are intended for Explosive Atmosphere use in accordance with ATEX Directive 2014/34/EU and UK Statutory Instruments 2016 No 1107. It is the user's responsibility to determine the suitability of this equipment for the intended purpose.

**CAUTION! THESE FANS ARE NOT INTENDED FOR USE IN MINES SUSCEPTIBLE TO FIRE-DAMP.**

**Explosion Proof Fan Rated:  
II 2 G Ex db eb IIB T6 Gb  
II 2 G Ex h IIB T6 Gb**

Euramco Safety hereby declares that the equipment listed in this manual conforms to the relevant Essential Health and Safety Requirements of the European Machinery Directive and standards listed below.

**Council of European Communities Directive:**  
Directive 2014/34/EU.

**Standards to which conformity is declared:**  
See "Declaration of Conformity"  
UK Statutory Instruments 2016 NO.1107

**Category, Group and Zone Classifications**  
According to ATEX Directive (2014/34/EU)  
According to UK Statutory Instruments 2016 NO.1107

**II 2 G Ex db eb IIB T6 Gb  
II 2 G Ex h IIB T6 Gb  
0539 Demko 09 ATEX 0926969X**

**IECEX UL 13.0062X**

**UL23UKEX2861X**

**Design of fans working in potentially explosive atmospheres EN 14986**

## Specific Conditions for Safe Use:



The letter "X" at the end of the ATEX, IECEx, UKCA and INMETRO certificate numbers indicate a specific condition for safe use. This specific condition of safe use refers to the fact that the Hazardous Location Fans referenced herein may be purchased with or without an AC power plug termination for the power cable.

If fans are purchased with unterminated power cables, (flying leads), then it becomes the responsibility, of the end user to select a compliant power plug in accordance with standard, IEC/EN/ABNT NBR IEC 60079-14 and to install the plug in accordance with the plug manufacturers instructions. Color code for flying lead power cables is brown "hot", blue "neutral", & yellow/green "ground" for plug connections.

If fans are purchased with power plug termination for the power cable, manufacturer's instructions for plug & coupler/socket type matching & installations must be followed.

If fans are purchased with the Aluminum enclosure 05 080806 specific condition of use: The empty enclosure with a coating must not be used in areas affected by charge-producing process, mechanical friction and separation process, electron emission (e.g. in the vicinity of electrostatic coating equipment), and pneumatically conveyed dust.

The flame proof joints are not intended to be repaired.

### T6 Temperature Classification:

85°C T6 - According to IEC 60079-0 / EN 60079-0 / ABNT NBR IEC 60079-0.

To ensure that there is no risk of ignition due to hot surfaces, the equipment is classified with regard to the maximum surface temperature of any part of the equipment while in operation based on the ambient temperature of 40°C. Equipment must be selected with a suitable temperature classification for the gases and vapors present where the equipment is to be installed. Ensure that the maximum surface temperature of any parts of the equipment are below the ignition temperature of the explosive atmosphere concerned.

This equipment is intended for use in ambient temperatures ranging between -20°C and +40°C.

Classification: Ex de

According to IEC 60079-1 / 60079-1 / ABNT NBR IEC 60079-1 Flame Proof  
Enclosures with Increased Safety Components IEC 60079-7 / EN 60079-7 /  
ABNT NBR IEC 60079-7

RAMFAN SAFETY VENTILATORS ELECTRICAL RATING				
Model No.	Euramco Part No.	Input Voltage	Frequency	Current
UB20xx	EF7002	115 VAC	50/60 HZ	2.3 A
	EF8002	230 VAC	50/60 HZ	1.2 A
EFi75xx	EB7201XX	115 VAC	50/60 HZ	8.8 A
	EB7201XX-230	230 VAC	50/60 HZ	4.4 A
EFi120xx	EA8120XX-110	110 VAC	50 HZ	10.8 A
	EA8120XX	240 VAC	50 HZ	5.5 A
EFi150xx	EG8200XX	115 VAC	50/60 HZ	15 A
	EG8200XX-230	230 VAC	50/60 HZ	8.1 A

## Description of Apparatus

The Portable Ventilator assemblies represented herein consist of an Approved Explosion Proof Electric Motor Rated: **Ex d IIB** as listed below.

RAMFAN SAFETY VENTILATORS				MOTOR
Model No.	Part No.	Input Voltage/ Frequency	Impeller	Motor part No.
UB20xx	EF7002 EF8002	115 VAC, 50/60 HZ 230 VAC, 50/60 HZ	Plastic	1933007415 1933007419
EFi75xx	EB7201XX EB7201XX-230	115 VAC, 50/60 HZ 230 VAC, 50/60 HZ	Metal	1133007405
EFi120xx	EA8120XX-110 EA8120XX	110 VAC, 50 HZ 240 VAC, 50 HZ	Plastic	1223007401
EFi150xx	EG8200XX EG8200XX-230	115 VAC, 50/60 HZ 230 VAC, 50/60 HZ	Plastic	1133007417

### The Flame Proof Electric Motor Power

Requirements: See chart above.

**Ambient Temperature Range:** -20°C<Tamb<+40°C

**Maximum Inlet Temperature:** 40°C

**Maximum Temperature Conveyed to Atmosphere:** 2°C above air inlet temperature

**Maximum Fan Casing Pressure:** 12" / 305mm w.g.

**Ingress Protection to IEC 529:** IP55

Marked: Electric Motor for Hazardous Locations.

### Flame Proof Enclosure: Ex d IIB

The electric motor consists of one flameproof enclosure, which contains less than 6% magnesium by weight. The on/off switch is housed within the motor enclosure, and is operated by a shaft, extending out from the rear end bell to a lever. The lever is accessible via an attached push rod.

Motor connections are made through a non-detachable cable, secured to the motor with an approved Flame Proof cable gland from the company Hawke, model 501/421/0/M20 and complies with International Standards EN 60079-0, EN 60079-1, and EN 60079-7. The electric motor drives an aluminum or plastic fan blade which is enclosed in a plastic, statically conductive housing with a conductivity rating of <1 giga ohms. Connection to the motor is facilitated by a Terminal Block mounted in an Increased Safety/Flame Proof Enclosure rated II 2 G Ex e II T6, from the company Rose Industries, Part Number 2608080600, and covered under ATEX Certificate No. PTB 00ATEX1002, the current UK certificate UL23UKEX2861X. This box was designed to conform to International Standards EN 60079-0, EN 60079-1, EN 60079-7, EN 60079-11, EN 60079-18, IEC/EN 60079-31. The enclosure features stainless steel grounding lugs, with a high heat silicon gasket.

The Flame Proof enclosure has attached, approved, explosion proof cable glands, as described below.

**Rated:** II G Ex e II

**Type:** Polyamide Ex metric conforms to International Standards EN 60079-0, EN 60079-1, EN 60079-7, IEC/EN 60079-31.

**Material:** Polyamide

**Grommet:** NBR

**Temperature Range:** -4°F to +212°F

**Color:** Black/Blue

**Protection Classification:** IP68

**Approval:** PTB 00 ATEX 1063

If the fan power cables are not terminated with power plugs see Specific Conditions for safe use.

## INSTRUCTIONS AND CARE

The fans are assembled with both Inlet and Outlet Safety Guards that conform to the safety standards to prevent danger zones being reached by upper limbs in the BS EN ISO 12100 Safety Machinery – Guards Standard.

### Installation and Start-Up

- During the installation and start-up of the RAMFAN blowers in areas where there is a risk of explosion:
- Design of the electrical installations must be in accordance with EN/IEC/ABNT NBR IEC 60079-14.
- Ensure power source is providing an electrical ground.
- Blowers must be integrated into a system in a way to support accessibility for regular maintenance.
- Blowers are designed for portable, nonfixed installation. Blowers have no mounting features to support rigid duct or fix installations.
- Perform careful inspection of each blower system to ensure ducting is securely attached to blower. All components of the blower system are made of electrically conductive material. It is very important to properly and securely attach each component to maintain a ground path.
- Inspect fan power cable and plug for damage or wear that could render the cable unsafe for hazardous locations.
- Ensure set-up, installation, operation and maintenance are performed only by properly trained personnel.
- Operation after a faulty installation or maintenance shall be considered as

### Before STARTING the FIRST time

DO NOT start operation if there are any signs of shipping damage to the blade, guards or housing. STOP, call your dealer. USE Ex-Rated receptacles for this equipment. IT IS NOT recommended to use extension cords for high amperage load. (See power rating label on limit).

## OPERATION

Always ensure the switch is in the “Down/OFF” position prior to connecting the ventilator to a power source.

Completely uncoil fan power cable to the AC power source.

Route fan power cable to avoid contact with heavy machinery that could possible damage cable or possible be a trip hazard for workers.

Connect plug end of the fan power cable to the AC power source. Verify AC power source is providing an electrical ground connection.

NOTE: For ATX connectors lift dust covers and insert plug into coupler until coupler dust cap latches snaps into position on plug. To break connection between coupler and plug lift dust cap to pull connectors apart.

NOTE: For CEAG connectors lift dust cover, insert plug into coupler, and rotate clockwise, to lock plug into coupler and to close power switch within the coupler. To break connection between coupler and plug lift dust cap and rotate plug counter-clockwise to pull connectors apart.

Note: For R.STAHL connectors insert plug into coupler and rotate outer ring clockwise to secure plug to coupler.

### See Illustrations (Pg.6)

Stop the blower if mechanical noise, vibration or other abnormal conditions occur. Any noise other than turbine-type pitch is not normal.

This unit is equipped with thermal overload protection with automatic reset. Motor will restart without warning after protector trips. To protect the user, disconnect unit and determine cause of protector trip.

Conductive RAMFAN Portable Ventilators are made with statically conductive materials. When ducting is required to remote the ventilator from the point of application in a potentially explosive environment, the ducting must be:

1. Statically Conductive, Surface resistance  $\leq 10^6$  ohms.
2. Flexible.

## MAINTENANCE

- Disconnect power before inspection, disassembly or cleaning.
- Never immerse or directly spray motor with liquids.
- Clean ventilator with commercially available biodegradable cleaning solutions. Do not use solvents containing hydrocarbons (i.e. MEK, Acetone).
- Inspect clearance between impeller tips and fan casing for minimum acceptable clearance with pin gauges as shown in picture below. Minimum acceptable impeller tip clearance is 0.079" / 2mm.



- Clean fan, impeller, & motor to remove accumulated dust or debris. Clean the impeller and motor with a damp cloth only, to avoid any possibility of a disruptive breakdown due to electrostatic charging.
- Inspect impeller & finger guards annually for damage. Replace as necessary.
- Inspect fan power cable and plug for damage or wear that could render the cable unsafe for hazardous locations.
- Disconnect fan power cable plug from the power source before cleaning. Never immerse or directly spray cable and plugs with fluids. Clean cables with commercially available biodegradable cleaning solutions. Do not use solvents containing hydrocarbons (i.e. MEK, Acetone).
- At a minimum, check power cables during maintenance work on the fans for:
  - Firm fit of the conductors.
  - Damage on the enclosure; seals or surface.
  - Dirt on the sleeves.
- To avoid electrostatic charging, the devices located in potentially explosive areas may only be cleaned using a damp cloth.
- When cleaning with a damp cloth, use water or mild, non-abrasive, non-scratching cleaning agents.
- Do not aggressive detergents or solvents.
- Prevent water and cleaning agents from penetrating the socket contacts.
- There are no user serviceable parts. Contact factory for replacement part applicability.
- Do not change make or model number of motors for any reason!

## A.T.X. Connector Installation and Removal

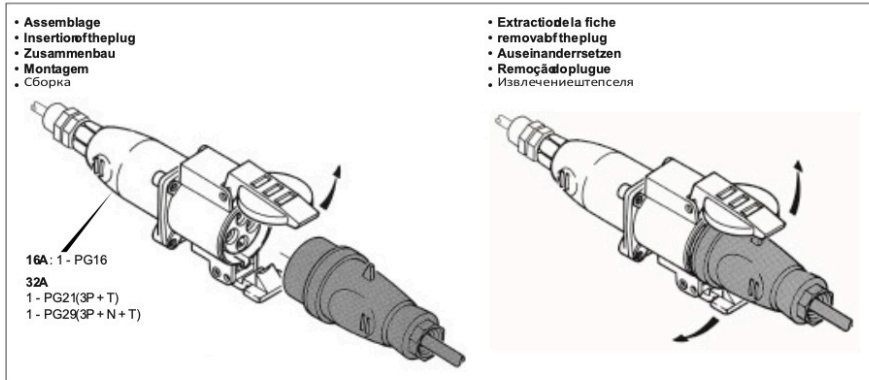

## CEAG Connector Installation and Removal



## STAHL Connector Installation and Removal

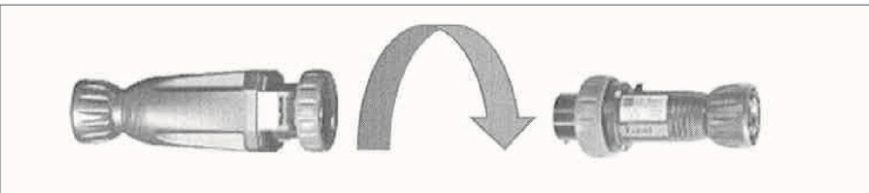

## CAUTIONS

Do not move ventilator while fan is in operation. Use good lifting practices when moving ventilator to prevent bodily injury.

Blower should be operated and repaired by trained personnel only.

Do not operate if there is any physical damage to cord, plug or receptacle.

Keep fingers and hands clear of fan blade. Keep fan guard securely in place. Do not operate with damaged or missing fan guards.

Use properly grounded power receptacle in potentially explosive atmospheres, and for operation safety. Ensure continuity to the earth.

Fatal electrical shock may result if motor frame and adjacent metal are not grounded in compliance with electrical code.

Keep area clear of rock and debris.

Keep away from children.

## WARRANTY

Positive Pressure Ventilators Turbo Ventilators and portable blowers, excluding motor and wear items, are warranted for one year from date of original purchase, to be free of defects in material and workmanship. Electric motors are warranted by their respective manufacturers. Wear items include feet, fasteners, handles, wheels, and paint are not covered under the warranty. Fan impellers and shrouds are warranted to be free of defects in material and workmanship for five years. Components exposed to salt water service are warranted for a period of one year from date of original purchase. Duct is not warranted due to its intended use.

**Authorization for warranty repairs must be obtained from the factory. There are no other warranties expressed or implied.**

## Fan Performance Characteristics

Fan performance is characterized as airflow as a function of backpressure. Backpressure is typically a function of the length of flexible duct attached to the fan.

Maximum airflow also referred to as free air occurs at 0 mm/ 0" w.g.

The first chart shows 4 performance curves for all four ATEX/UKCA fans running on 50Hz AC power. The second chart show 3 performance curves for three of the ATEX/UKCA fans, running on 60Hz. Please note that the EF120xx is not designed to run efficiently on 60Hz AC power and does not appear on the 60Hz chart for this reason.

### Fan Performance Characteristic for Fans Running on 50Hz AC power

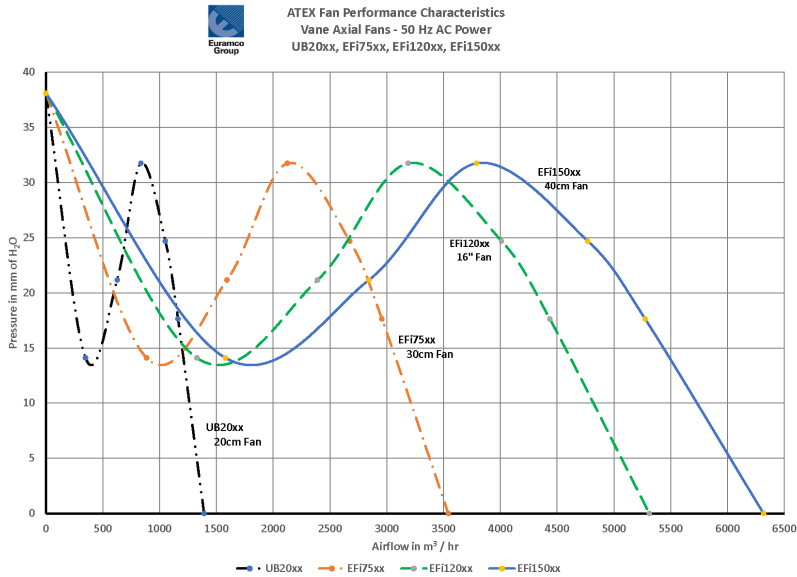

### Fan Performance Characteristic for Fans Running on 60Hz AC power

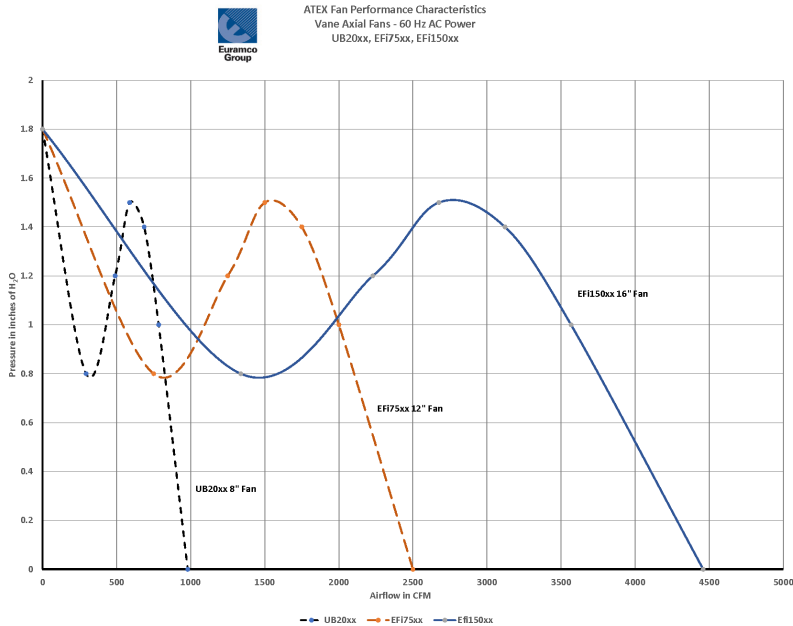

### TYPICAL VENTILATOR EXPLODED VIEW ACCESSORIES FOR ATEX, UKEx, IECEx AND INMETRO HAZARDOUS LOCATION FANS

Euramco Group has several optional antistatic / conductive airflow duct accessories designed explicitly for use with our Hazardous Location Fans to support various end user applications as identified in the list below.

#### ACCESSORIES LIST

Fan Model	Accessory P/N	Description	
UB20xx	EF7004CS	Quick-Couple Canister with 8" x 15' Duct, Antistatic	
	EF7004CL/DS	Quick-Couple Canister with 8" x 5' & 8" x 15' Duct, Antistatic	
	EF7004CL/DL	Quick-Couple Canister with 8" x 5' & 8" x 25' Duct, Antistatic	
	EF7004CL	Quick-Couple Canister with 8" x 25' Duct, Antistatic	
	FDT-0815CBB	Duct, 8" x 15', Antistatic with Belt and Belt	
	FDT-0825CBB	Duct, 8" x 25', Antistatic with Belt and Belt	
	EF0304X	Duct Adapter, 8" / 20cm	
	DC8	Duct Coupler, 8", Stainless Steel	
	MED189XX	Manhole Entry Device, Conductive	
	MED90XX	MED 90° Elbow, Conductive	
EFi75xx	MED5100XX	Manhole Entry Device (MED), Conductive, Assembly	
	MEDIUM	MED Universal Mount	
	FDT-1215CBB	Duct, 12" x 15', Antistatic with Belt and Belt	
	FDT-1225CBB	Duct, 12" x 25', Antistatic with Belt and Belt	
	EC0301	Duct Adapter, 12"/30cm to 8"/20cm	
	DC12	Duct Coupler, Stainless Steel	
	EB 5006	Duct Adapter, 12" to 10" Reducer	
	EFi120xx & EFi150xx	FDT-1615CBR	Duct, 16" x 15', Antistatic with Belt and Ring
		FDT-1625CBR	Duct, 16" x 25', Antistatic with Belt and Ring
		FDT-1625CBB	Duct, 16" x 25', Antistatic with Belt and Belt
EA7106		Duct Adapter, 16" / 40cm	
DC16	Duct Coupler, Stainless Steel		

TYPICAL VENTILATOR EXPLODED VIEW

UB20XX EF7002 / EF8002

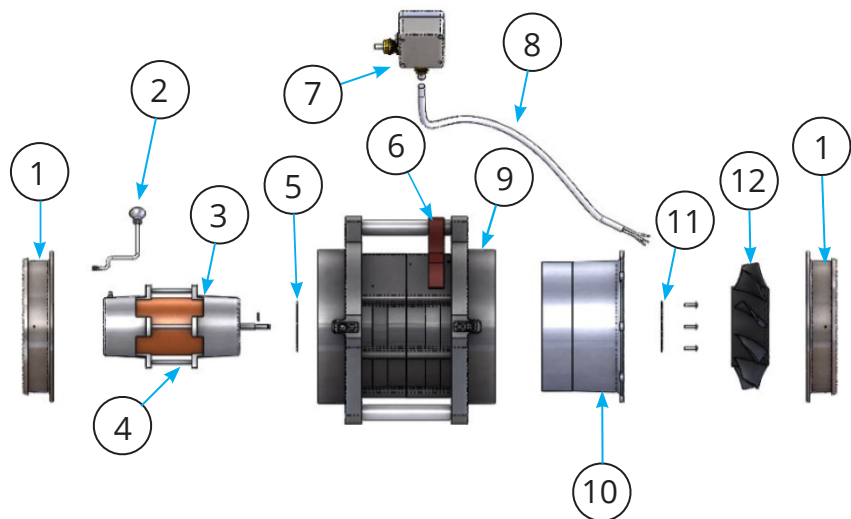

- |                                  |                                    |
|----------------------------------|------------------------------------|
| 1. E7205K – DUCT ADAPTER KIT     | 7. EZ-080305003CE – JUNCTION BOX   |
| 2. EF7019 – PULL ROD             | 8. EZ-H07RN-F3/1.5MM – POWER CABLE |
| 3. EM-F.33-60XPEX – EF7002 MOTOR | 9. EF7105AC – HOUSING, CONDUCTIVE  |
| 4. EM-F.33-230VXP – EF8002 MOTOR | 10. ST010 – STATOR                 |
| 5. ED0170 – MOTOR MOUNTING RING  | 11. ED0170 – MOTOR MOUNTING RING   |
| 6. EZ-312-RWB – CORD STRAP       | 12. BL011 – IMPELLER               |

TYPICAL VENTILATOR EXPLODED VIEW

EFi75XX EB7201XX / EB7201XX-230

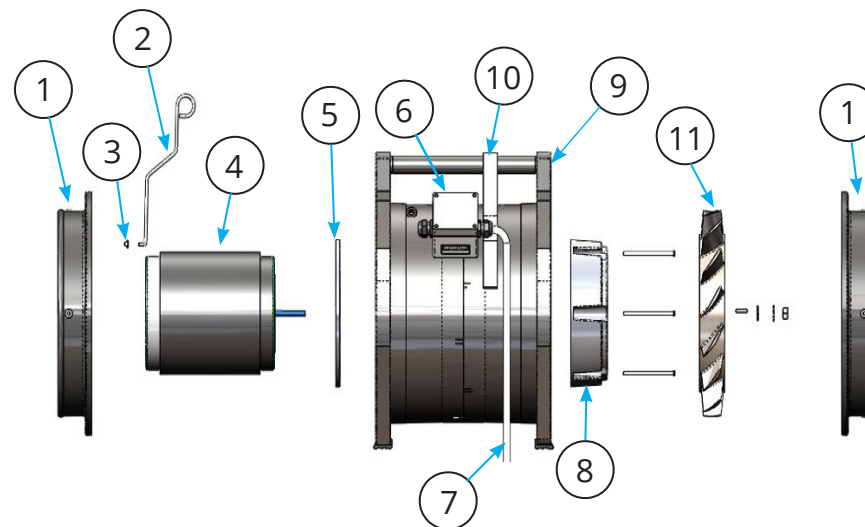

- |   |                                     |
|---|-------------------------------------|
| 1. EB7006K – DUCT ADAPTER KIT                           | 7. EZ-H07RN-F3/2.5MM – POWER CABLE  |
| • EB5006 – ALTERNATIVE DUCT ADAPTER, 12" TO 10" REDUCER |                                     |
| 2. EB7018 – EFi75xx SWITCH ROD                          | 8. EA7007 – ADAPTER CASTING, C-FACE |
| 3. EZ-CAP-A027 – PUSH CAP                               | 9. EB7201XXHA – 12" HOUSING ASSY    |
| 4. EM-F.75-60XPEX – MOTOR                               | 10. EZ-312-RWB – CORD STRAP         |
| 5. EA7004 – FLANGE                                      | 11. BL008 – IMPELLER                |
| 6. EZ-080305002CE – JUNCTION BOX                        |                                     |

TYPICAL VENTILATOR EXPLODED VIEW

EFi120XX EA8120XX / EA8120XX-110

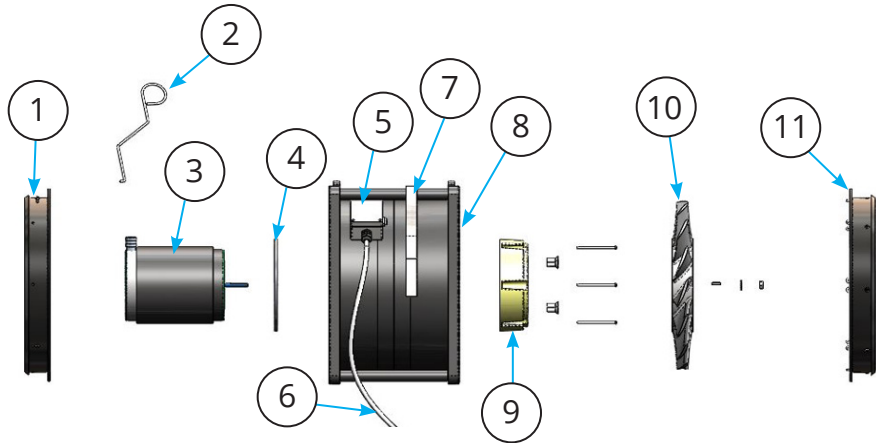

1. EA7117 – 16"/40cm DUCT ASSY ( <i>EXHAUST</i> )	7. EZ-312-RWB – CORD STRAP
2. EC7018 – SWITCH ROD	8. EA7001AC – HOUSING ASSY
3. EM-F.85-50XPDV – MOTOR	9. EA7007 – ADAPTER CASTING, C-FACE
4. EA7004 – FLANGE	10. BL906 – IMPELLER
5. EZ-080305002CE – JUNCTION BOX	11. EA7116 – 16"/40cm DUCT ASSY ( <i>INLET</i> )
6. EZ-H07RN-F3/2.5MM – POWER CABLE	

TYPICAL VENTILATOR EXPLODED VIEW

EFi150XX EG8200XX/ EG8200XX-230

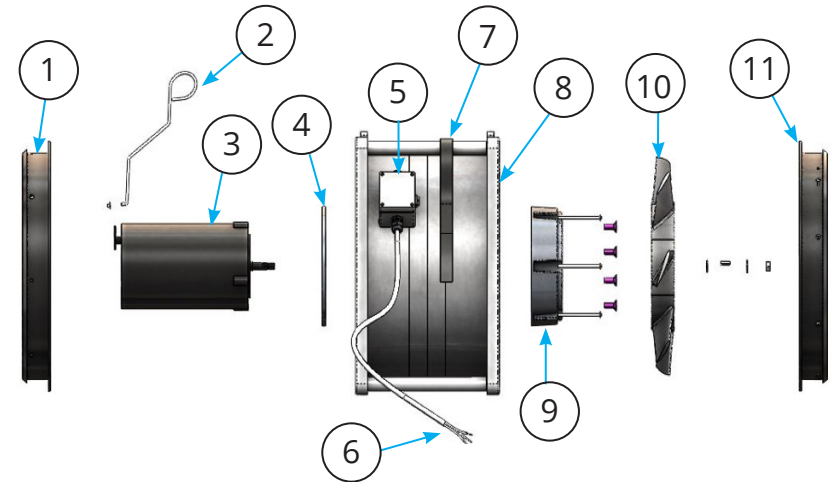

1. EA7117 – 16"/40cm DUCT ASSY ( <i>EXHAUST</i> )	7. EZ-312-RWB – CORD STRAP
2. EC7018 – SWITCH ROD	8. EG8200XXHA – HOUSING ASSY
3. EM-F1.5-60/50XPEX – MOTOR	9. EA7007 – ADAPTER CASTING, C-FACE
4. EA7004 – FLANGE	10. BL914 – IMPELLER
5. EZ-080305002CE – JUNCTION BOX	11. EA7116 – 16"/40cm DUCT ASSY ( <i>INLET</i> )
6. EZ-H07RN-F3/2.5MM – POWER CABLE	

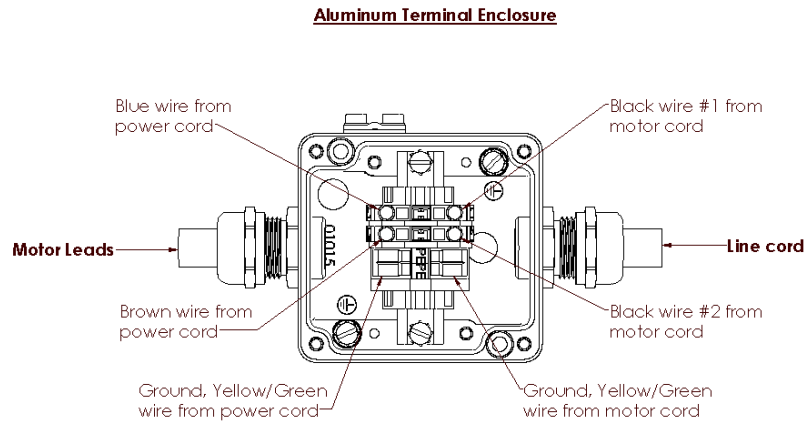

## WIRING DIAGRAM



## DECLARATION OF CONFORMITY

### DECLARATION OF CONFORMITY ATEX & UKEx Certified Portable Fans

This Declaration of Conformity is issued for ATEX & UKEx certified, flame proof, increased safety, portable fans, intended for use in potentially explosive atmospheres, manufactured by Euramco Safety, Inc. as referenced herein.

<b>Issue Date:</b>	April 2, 2024
<b>Manufacturer:</b>	Euramco Safety, Inc. 2746 Via Orange Way Spring Valley, CA 91978 USA
<b>Equipment Descriptions:</b>	UB20xx            8" / 20 cm ATEX Blower Exhauster EF175xx        12" / 30 cm ATEX Blower Exhauster EF120xx        18" / 40 cm ATEX Blower Exhauster EF150xx        18" / 40 cm ATEX Blower Exhauster
<b>Hazardous Location Rating:</b>	 II 2 G Ex db eb IIB T6 Gb  II 2 G Ex h IIB T6 Gb Zone 1, 2 T6, non-mining gases up to 85°C
<b>Certification Number:</b>	0539 DEMKO 09 ATEX 0926969X
<b>IECEx Certification Number:</b>	IECEx UL 43.0062X
<b>Notification Number:</b>	10 ATEX Q437286
<b>UKEx Certification Number:</b>	UL23UKEX2861X
<b>Notified Body:</b>	UL International DEMKO A/S, Notified Body Number 0539 Borupvang 5A 2750 Ballerup, Denmark
<b>Standards to which Certificate Applies:</b>	EN 60079-0:2018 EN 60079-1:2014 EN 60079-7:2015+A1:2018 EN 14986:2017
<b>Self-Declared Compliance Directives:</b>	2006/42/EC – Machinery Directive 2014/30/EU – EMC Directive 2011/65/EU – RoHS – Reduction of Hazardous Substances Directive

**Specific condition of use:**

- 1) This special condition of safe use refers to the fact that the Hazardous Location Fans may be purchased with or without an AC power plug termination for the power cable. The flame proof joints are not intended to be repaired.
- 2) The empty enclosure, with a coating, must not be used in areas affected by charge-producing processes, mechanical friction and separation processes, electron emission (e.g. in the vicinity of electrostatic coating equipment), and pneumatically conveyed dust.  
This applies to the aluminum enclosure box type: 05.XX XX XX.

Euramco Safety, Inc. hereby declares that equipment described above conforms with the protection requirements of ATEX Council Directive 2014/34/EU & UKEx on the approximation of the laws of the Member States Concerning Equipment and Protection Systems Intended for use in Potentially Explosive Atmospheres.



  
Wayne Allen  
President and CEO

04/02/2024

SM-EFATEX REV H5

**USA Headquarters**

2746 Via Orange way  
Spring Valley, CA  
91978 USA  
Toll Free: (800) 472-  
6326  
Phone: +1 (619)  
670-9590  
Fax: +1 (619) 670-7345

**Europe**

68 Avenue De La  
Liberte  
L-1930 Luxembourg,  
Luxembourg  
VAT Nr LU  
18816418

**MIDDLE EAST**

Dubai Logistic City  
Dubai,  
United Arab Emirates

**CHINA**

No. 128, Hezhou Road  
Ningbo, Zhejiang,  
China

**SINGAPORE**

1 Fullerton Road  
#02-01 One Fullerton  
Singapore 049213  
Tel : +65-9773 33 35